



Model MQ1226+APC Shown

KEY FEATURES:

- 7" Marine Grade, Hi-Res Touch Screen
- Automatic Pressure Control (APC)
- Product Vessels with 316 SS Pressure Ports
- 40 sq. ft. Pre-filter with PVC Core, and Pressure Monitoring and Alarming
- TEFC Continuous-duty Washdown Rated Motors
- Efficient Feed Pump with Closed Impeller Design
- NEMA 4X Rated Electrical Enclosure
- Programmable Automatic Fresh Water Flush
- Non-proprietary Membranes
- Available in Framed and Modular Configurations

STILL THE WORLD'S FINEST WATERMAKER.

The **Max-Q+** and **Max-Q+APC** are the latest evolution of the Max-Q product line. Our exclusive V4 control system utilizes a high resolution marine-grade 7-inch touch screen panel with an advanced intuitive interface. Operating and controlling a watermaker has never been easier. With the optional APC, Automated Pressure Control, making water is literally a touch away.

FCI has been manufacturing watermakers and water purification equipment for over three decades. We design and manufacture all of our equipment in-house for optimum quality control, and to ensure you are getting the most reliable watermaker on the market today. You have the comfort of knowing a company which has been in business for over 30 years, and specializing in only watermakers, is here for you.

THE INDUSTRY'S MOST RELIABLE WATERMAKER PUTS COMPLETE AUTOMATION AT YOUR FINGERTIPS.

FCI's next generation controller and interface allows customization of your watermaker through intuitive advanced touch screen controls. Our monitors' higher heat tolerance and system design allows it to work in the harshest environments. FCI touch screen controllers can be installed with confidence, because they are Bridge Classified for marine use with Type Approval Certifications from: ABS, GL, Lloyd's Register EMEA, Det Norske Veritas, and Russian Maritime Register of Shipping.

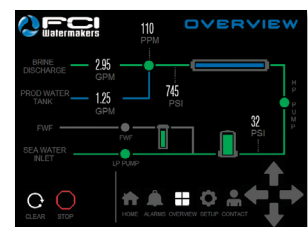
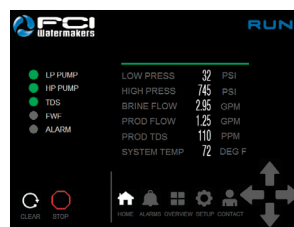
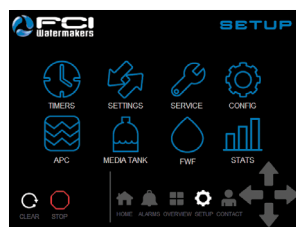

FEATURES

- **MOTORS:** TEFC continuous-duty washdown rated motors with 316 SS shaft, and sealed maintenance-free bearings for long life applications.
- **LP FEED PUMP:** Closed impeller design offers 50% more pressure efficiency over standard pumps.
- **ELECTRICAL:** NEMA 4X rated enclosure.
- **HMI TOUCH SCREEN:** 7" High-resolution, Marine Grade and Bridge Certified.
- **OPEN FRAME DESIGN:** Allows easy visual inspection and access for maintenance.
- **CONNECTIONS:** Easily accessed to simplify installation along with a oil drain.
- **FRESH WATER FLUSH:** Schedule automated flushes through the V4 Control.
- **MEMBRANES:** High Rejection non-proprietary membranes used to obtain the highest quality of product water.
- **AUTOMATED PRESSURE CONTROL (APC):** Auto-adjusts system pressure to feed water conditions.
- **PRODUCT VESSELS:** 316 SS product/pressure ports, and FDA/NSF-51 fittings used on the product water.
- **PRE-FILTER:** 40 sq. ft. of pleated filter with PVC core in addition to pressure monitoring and alarming.

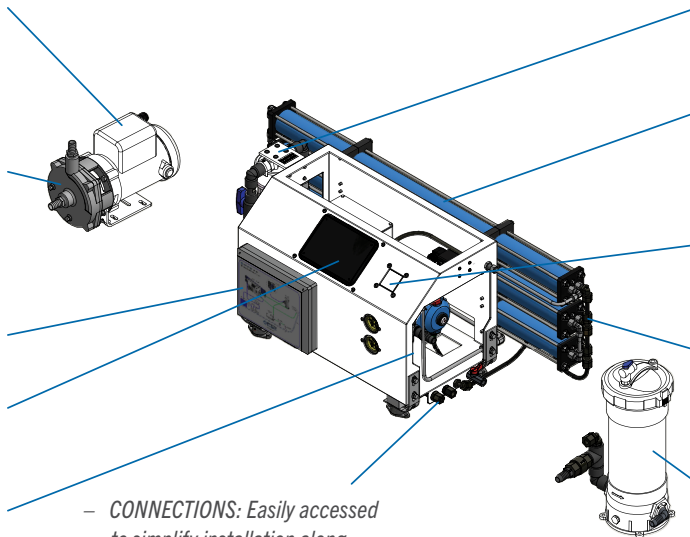

DIMENSIONS

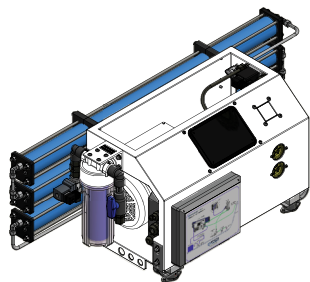

UNIT WIDTH

Frame Only	25.00 in / 635.00 mm
with FWF Filter	31.00 in / 787.40 mm
with Membranes	47.15 in / 1197.61 mm

UNIT DEPTH

Frame Only	15.30 in / 388.62 mm
with Membranes	19.55 in / 496.57 mm

UNIT HEIGHT

Frame	17.00 in / 431.80 mm
-------	----------------------

AVAILABLE PRODUCT OPTIONS

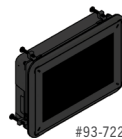

#93-7225

V4 REMOTE 7"

Width	8.04 in / 204.22 mm
Depth	2.13 in / 54.10 mm
Height	5.64 in / 143.26 mm



#93-7224

V4 REMOTE 4.3"

Width	5.71 in / 145.03 mm
Depth	2.13 in / 54.10 mm
Height	4.09 in / 103.89 mm



PRE-FILTER

Width	11.10 in / 281.94 mm
Depth	9.60 in / 243.83 mm
Height	20.50 in / 520.70 mm

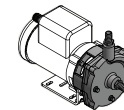

LP PUMP

Width	7.15 in / 181.61 mm
Depth	15.90 in / 402.86 mm
Height	10.80 in / 274.32 mm

REQUIREMENTS

UTILITIES

Inlet	Brine	Product	FWF
3/4" FNPT	1/2" Tube	3/8" Tube	1/2" Tube

ELECTRICAL

HP	KW	VAC	HZ	PH
2.5	2.24	120 / 208-240 / 380 / 480	50 / 60	1 / 3

MODEL

Manual / Auto (Pressure Control)	Weight (LBS / KG)	Seawater (GPD / LPD)	Seawater (GPH / LPH)	Commercial Filter Standard	316SS High Pressure Pump	700 GPD	1275 GPD	1850 GPD	V4 Control System
MQ726+ / MQ726+APC	195 / 43.10	700 / 2649.79	29.17 / 110.42	☑	☑	☑			☑
MQ1226+ / MQ1226+APC	205 / 92.99	1275 / 4826.40	53.13 / 201.12	☑	☑		☑		☑
MQ1826+ / MQ1826+APC	215 / 97.52	1850 / 7003.01	77.10 / 291.86	☑	☑			☑	☑

System Rated Based on Typical Sea Water Conditions: Temperature 77° F / 25° C | TDS 32,000 | Pressure 825 PSI

The Filtration Concepts Incorporated, dba FCI Watermakers, General Terms and Conditions of Sale and applicable Warranty are incorporated herein and applicable to this Product. FCI's Customer Service Department can provide Purchaser with a copy of the General Terms and Conditions of Sale upon request.